

Relative Intensity Noise of Distributed Feedback Laser

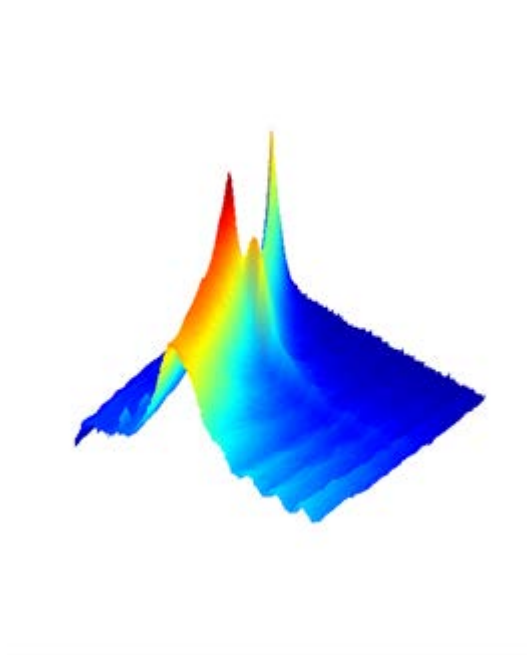

Table of contents

1	Introduction	2
2	Setup	2
3	Definition of <i>RIN</i> and noise sources.....	3
3.1	Thermal noise.....	3
3.2	Shot noise	4
3.3	Laser noise	4
3.4	Average electrical power	4
3.5	Calculation of <i>RIN</i>	5
4	Measurement.....	5
4.1	Single <i>RIN</i> value.....	5
4.2	<i>RIN</i> against pump current	7
5	Abbreviations	7

1 Introduction

Relative intensity noise (*RIN*) describes fluctuations in the optical power of a laser, which, in the case of our Distributed Feedback Lasers (DFB), mainly stem from intrinsic optical phase and frequency fluctuations caused by spontaneous emission. However, the measured *RIN* value depends strongly on the current noise and the quality of the measurement setup, both of which differ from lab to lab. This application note aims to provide you with our measurement method and the theoretical background that underlies our analysis in order to clarify the way we determine *RIN*.

Since the determination of *RIN* is relatively sophisticated and time consuming, we carry out this measurement only on DFB samples. If you would like a *RIN* measurement of your DFB before shipment, please let us know ahead of time.

2 Setup

In order to avoid back reflections into the DFB, an optical isolator is placed between the collimating lens L1 and the focusing lens L2. The beam is coupled into a single-mode fiber. The other end of the external SM fiber is plugged into the chassis of the detector. As depicted in Figure 1, the detector is connected to a SM fiber. Both the detector and the single-mode fiber are within a chassis to which the external fiber is connected via a fiber plug.

At the bias branching point the DC and the AC signal of the photo current are separated. The AC signal is amplified and measured with the electrical spectrum analyzer (ESA). The DC part is measured at R_{out} .

For a driver we use a low noise current source together with a low noise CW Filter.

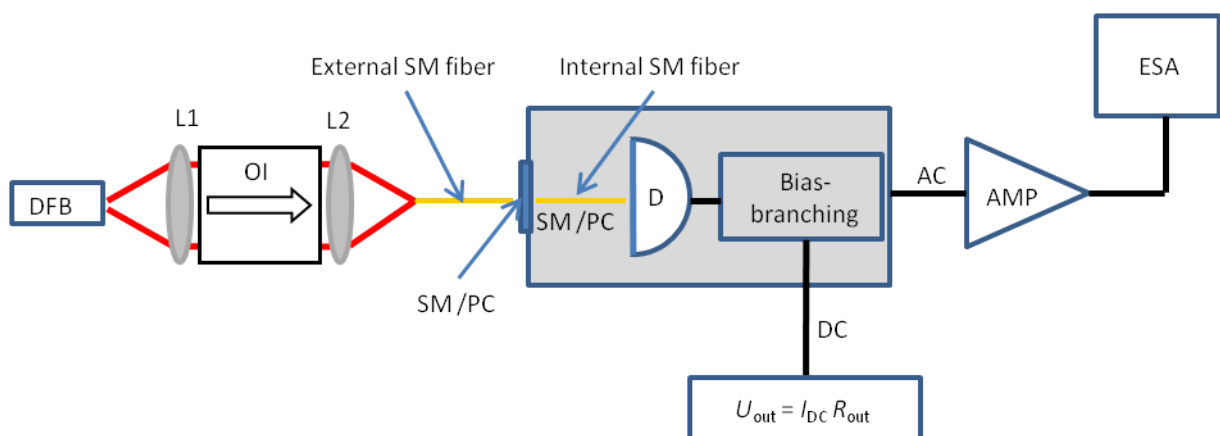

Figure 1: DFB: Distributed Feedback Laser, OI: Optical Isolator, D: Photodetector, AMP: Amplifier, ESA: Electrical Spectrum Analyzer

3 Definition of *RIN* and noise sources

According to EN ISO 11554:2003 relative intensity noise is defined as

$$RIN_T = \frac{\langle \Delta P(t)^2 \rangle}{P_0^2}, \quad [1]$$

where P_0 is the average optical power and $\Delta P(t)$ represents the fluctuations of optical power. Optical power is detected with a fast photo detector, and thus the optical power fluctuations are transformed into electrical power fluctuations which are measured with an ESA (electrical spectrum analyzer). Squared optical power is proportional to the detected electrical power

$$P_E \propto i^2 \propto P_{opt}^2, \quad [2]$$

so *RIN* can be expressed through the corresponding electrical values

$$RIN_T = \frac{\Delta P_E}{P_{E0}}, \quad [3]$$

where ΔP_E is the overall noise, measured in power spectral density per Hertz and P_{E0} the average electrical power. The overall noise ΔP_E has three noise components:

$$\Delta P_E = N_L + N_q + N_{th}. \quad [4]$$

N_L : DFB-noise

N_q : shot noise

N_{th} : thermal noise

3.1 Thermal noise

With laser off, eq. [4] simplifies to

$$\Delta P_{E_off} = N_{th}. \quad [5]$$

Thus, without optical power only the thermal noise is measured with the ESA.

3.2 Shot noise

Shot noise N_q appears at the photo-detector and rises proportionally to the detected optical power. It can be determined by the measurement of the photo current at the photo-diode according to

$$N_q = 2 \cdot q \cdot I_{DC} \cdot R_L, \quad [6]$$

where I_{DC} is the photo current at the load resistance R_L and q is the elementary charge. The photo current can be determined by measuring the average optical power P_0 that reaches the photo detector according to

$$I_{DC} = r \cdot P_0, \quad [7]$$

where r is the responsivity of the photodetector.

Since the losses at the fiber plug (See Setup in Chapter 2) and the amount of optical power that impacts on the detector are specified only approximately, the optical power P_0 has to be determined indirectly by measuring the voltage U_{out} over the output resistance.

$$P_0 = \frac{U_{out}}{r \cdot R_{out}} \quad [8]$$

Inserting [8] and [5] into [6] yields

$$N_q = 2 \cdot q \cdot U_{out} \frac{R_L}{R_{out}}. \quad [9]$$

3.3 Laser noise

According to eq. [4], laser noise is determined by

$$N_L = \Delta P_E - N_{th} - N_q. \quad [10]$$

The overall noise ΔP_E is measured with the ESA with laser on. Thermal noise N_{th} and shot noise N_q result from equations in sections 3.1 and 3.2, respectively.

3.4 Average electrical power

As with the determination of shot noise, average electrical power can be calculated from the photo current I_{DC} :

$$P_{el} = (I_{DC}^2 \cdot R_L) \cdot V, \quad [11]$$

where R_L is the load resistance and V the amplification factor of the amplifier. (The DC-current is indeed not amplified, nevertheless the amplification factor must be taken into account for the sake of comparison. See equation [13].)

The I_{DC} current can be determined by

$$I_{DC} = \frac{U_{out}}{R_{out}}. \quad [12]$$

3.5 Calculation of RIN

After translation of N_L and P_{el} into logarithmic values L_L and L_{el} , RIN can be calculated by

$$RIN_T = 10^{0,1(L_L - L_{el})} = L_L - L_{el}. \quad [13]$$

4 Measurement

To measure one RIN value at a specific diode current, we conduct one measurement with laser on to determine the overall noise ΔP_E , and one measurement with laser off to determine the thermal noise N_{th} .

4.1 Single RIN value

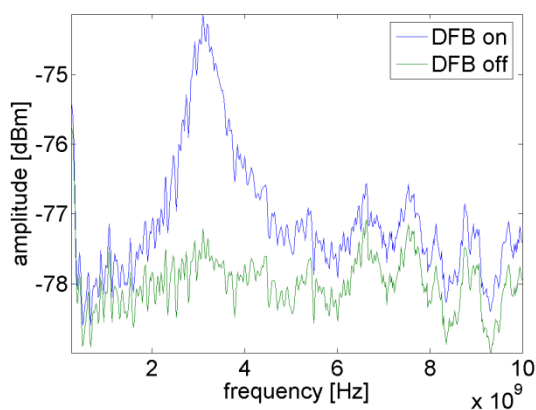

Figure 2: Noise spectrum with DFB on and off of our R&D diode at $I_{pump} = 110$ mA.

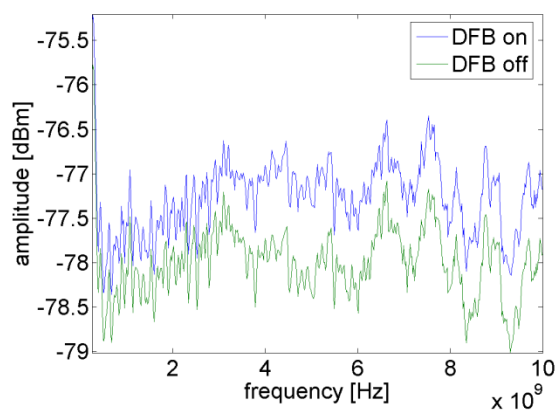

Figure 3: Noise spectrum with DFB on and off of our standard diode at $I_{pump} = 110$ mA.

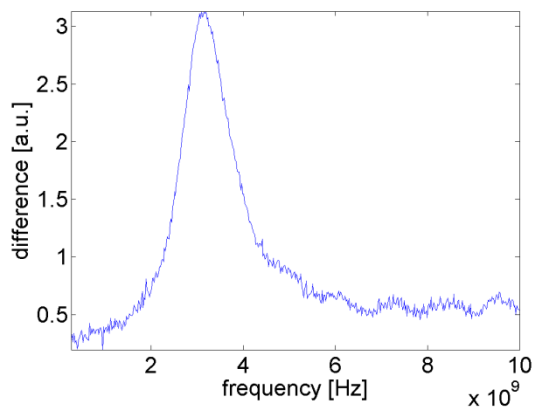

Figure 4: Difference spectrum from the spectra above.

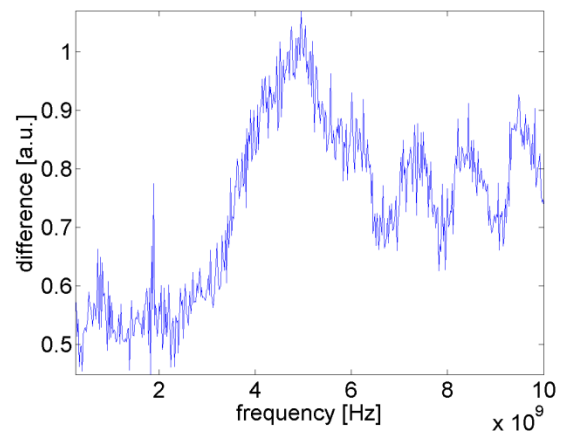

Figure 5: Difference spectrum from the spectra above.

For the determination of RIN , only the maximum power level in the spectrum at one frequency is relevant. As shown in Figure 2, for a very noisy DFB, the maximum power level can be obtained directly from the spectrum with laser on. For a low noise DFB, as shown in Figure 3, in the first step the frequency at which the maximum power level appears is obtained from the difference power-spectrum as shown in Figure 5. In the second step the respective power level at the obtained frequency is determined from the spectrum with laser on.

The voltage over the output resistance U_{out} for the determination of the shot noise N_q and the average electrical power P_{el} is measured with a multimeter. The RIN value is calculated with the equations [10], [11] and [13].

4.2 *RIN* against pump current

Figure 6 shows the difference power spectrum against pump current.

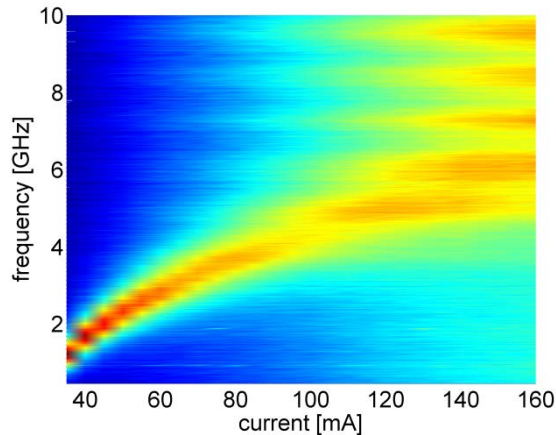

Figure 6: Difference power spectrum against the pump current of our standard DFBs

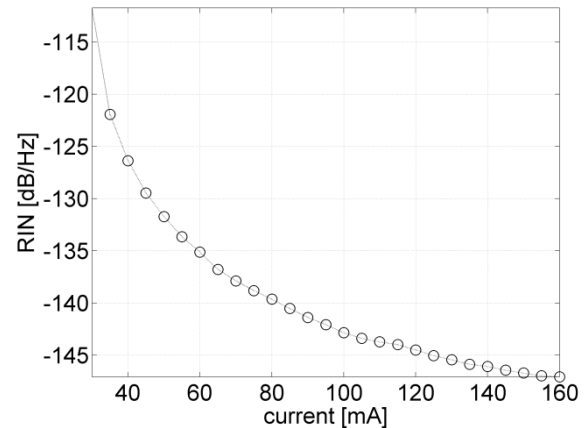

Figure 7: Calculated *RIN* values

The maximum power level shifts with increasing pump current to higher values in accordance with the theoretical relationship between frequency and pump current:

$$\nu \sim \sqrt{I - I_{th}}. \quad [14]$$

Figure 7 shows typical values of *RIN* against power of our DFBs. Note that the noise of the DFB declines at a higher pumping current. As observable in Figure 6 the noise of the ESA is higher than the noise of the diode above $I_{pump} > 120$ mA, so that the maximum power level of the noise spectrum of the DFB cannot be obtained at this range. Hence the noise of the ESA is taken as a reference maximum power level. Since the average electrical power increases (see equation [3]) the *RIN* value declines even at constant maximum power level as seen in Figure 7.

5 Abbreviations

RIN	relative intensity noise
DFB	distributed feedback laser
ESA	electrical spectrum analyzer
SM	single mode
AC	alternating current
DC	direct current